

HP 5000
Cut Sheet
Printers

**3,000-Sheet HCO
Installation and User Manual
Model D640**

HP 5000: Model D640 3000-Sheet HCO Installation and User Manual

Hewlett-Packard Company

C5638-90001

E1097



Notice

Hewlett-Packard makes no warranty of any kind with regard to this material, including, but not limited to, the implied warranties of merchantability and fitness for a particular purpose. Hewlett-Packard shall not be liable for errors contained herein or for incidental or consequential damages in connection with the furnishing, performance, or use of this material.

Hewlett-Packard assumes no responsibility for the use or reliability of its software on equipment that is not furnished by Hewlett-Packard.

This document contains proprietary information which is protected by copyright. All rights are reserved. No part of this document may be photocopied, reproduced, or translated to another language without the prior written consent of Hewlett-Packard Company. The information contained in this document is subject to change without notice.

Printing History

The dates on the title page change only when a new edition is published.

Edition 1.0.October 1997

Copyright ©1997 Hewlett-Packard Company

All rights reserved.

October 1997

Please address any comments or questions to:

Publications Manager
System Peripherals Operation
HP5000 Printers - MS 44MC

Hewlett-Packard Company
19111 Pruneridge Avenue
Cupertino, CA 95014

Copyrights and Trademark Credits

Adobe™, *PostScript™*, PostScript II and the *PostScript Logo™* are trademarks of Adobe Systems Incorporated which may be registered in certain jurisdictions.

Other product names mentioned in this manual may also be trademarks and are used here for identification only.

Contents

1. Introduction

Related documents	1
Installing the HCO	2
Unpacking the HCO	2
Checking the accessories	4
Assembling the HCO	6
Preparing the printer	10
Connecting the HCO to the printer	18
Connecting cables and powering up	19
Configuring the HCO	21

2. Using the HCO

Adjusting the paper stopper and guides	23
Adjusting the paper stopper	24
Adjusting the paper guides	25
Clearing an HCO paper jam	26
Clearing the HCO	26
Separating the HCO from the printer	28
Messages	30

3. Specifications, Regulatory Information

Specifications	33
HCO paper handling specifications	33
HCO physical specifications	34
HCO electrical specifications	34
HCO environmental specifications	34
Safety and regulatory information	35
Australia EMC	35
HP Declaration of Conformity	36

Index

1 Introduction

This manual describes how to install and use the 3,000-sheet High-Capacity Output (HCO) on your Hewlett-Packard 5000 Model D640 printer. The HCO supports a variety of paper sizes and can handle up to 40 pages per minute (ppm).

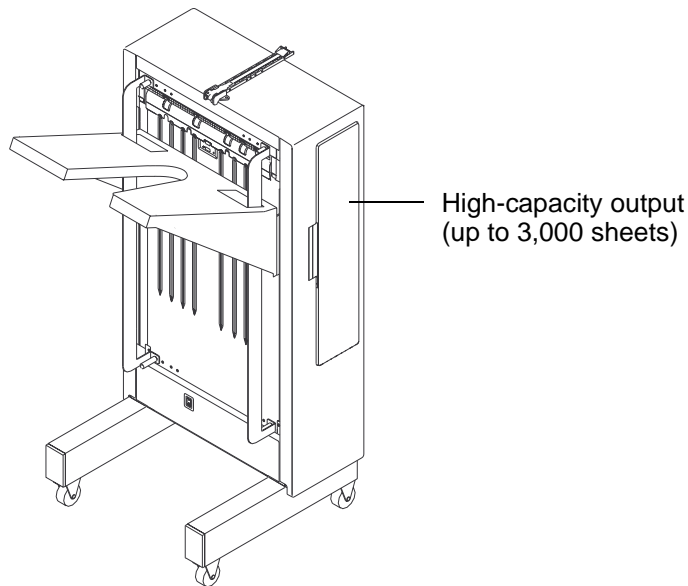

Figure 1 High-capacity output for Model D640 printer

Related documents

The information in this manual supplements the following documents:

- *Model D640 Installation Manual*
- *Model D640 User Manual*

If you're using the 3,000-sheet HCO, the installation procedures in this manual replace the HCO installation procedures in the *Model D640 Installation Manual*.

Installing the HCO

Note

Before you connect the HCO to your printer, make sure the printer power is turned off.

Unpacking the HCO

The HCO is shipped separately from your printer. The outer carton contains the HCO and the HCO accessories box. Unpack the HCO accessories before you unpack the HCO.

WARNING!

The HCO weighs over 66 pounds (30 kilograms). To prevent injury, follow these instructions to unpack the HCO.

To unpack the HCO:

Step 1 Remove the accessories box from the outer carton. See Figure 2.

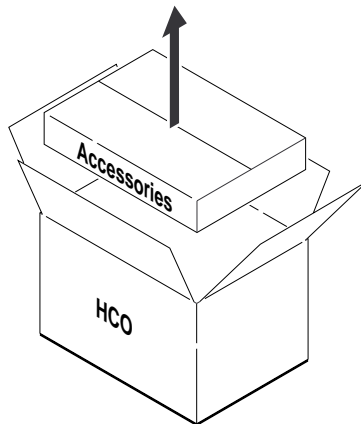

Figure 2 Unpacking the accessories box

Step 2 Remove the power cable and user manual (near the HCO's legs).

Step 3 Grasp the HCO box and set it upright. Then, remove the cardboard on top of the HCO.

The HCO's legs and casters should rest on the bottom of the box.

Step 4 Grasp the top and bottom of the HCO and roll it slowly out of the box. Make sure the HCO doesn't fall back as you roll it from the box. See Figure 3.

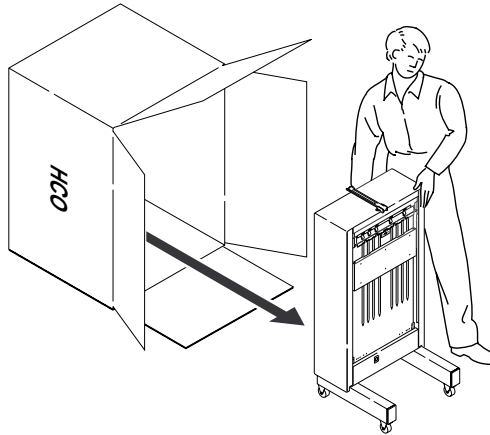

Figure 3 Removing the HCO

CAUTION

When you unpack and install the HCO, do not use the paper input guide on the back of the HCO to move or lift the HCO. You might damage the guide.

Step 5 Remove the plastic bag and all the packing tape from the HCO and set the packing material aside.

Don't forget to open the HCO door and remove the tape on the paper guides inside the HCO. Otherwise, paper jams will occur.

It's a good idea to save the packing material in case you need to ship the HCO in the future.

Checking the accessories

Before you set up the HCO, use this checklist to make sure you've received all the accessories.

HCO accessories checklist

<input type="checkbox"/> HCO (and attached interface cable)
<input type="checkbox"/> Tray
<input type="checkbox"/> Paper guides (with captive knurled screws), quantity = 2
<input type="checkbox"/> Stopper
<input type="checkbox"/> Stopper guide (and 2 captive screws)
<input type="checkbox"/> Paper output guide
<input type="checkbox"/> Joining frame (and 4 captive screws)
<input type="checkbox"/> Power cable, user manual, and screw driver (Not shown below.)

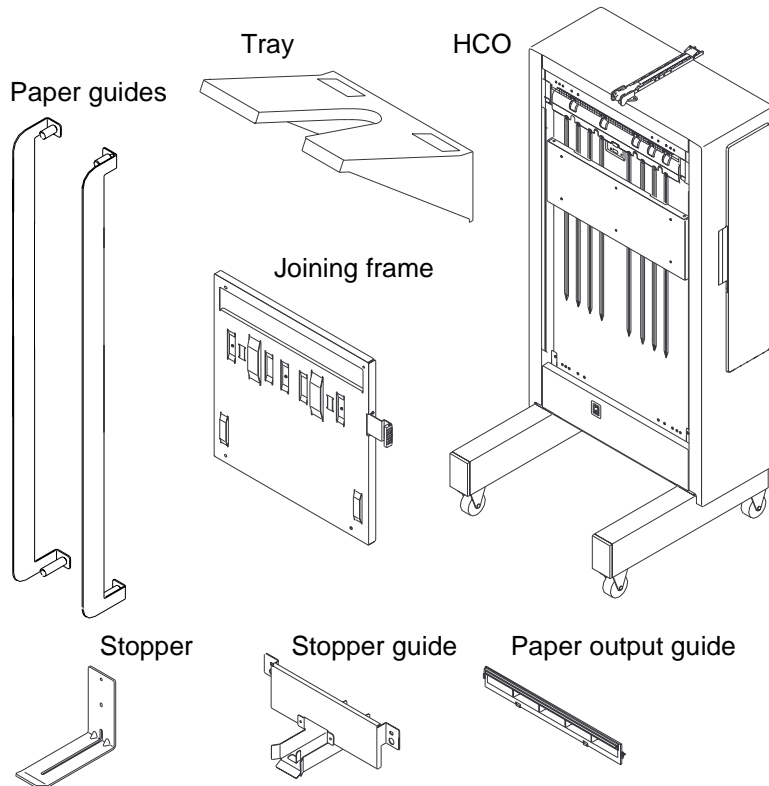
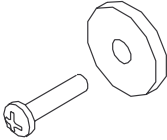

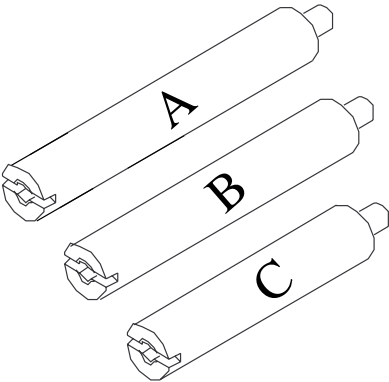

Figure 4 HCO and accessories

The following table shows the screws and bolts you need to install the HCO. These are included with the HCO accessories.

Screws and bolts

	Examples	Description	Quantity
<input type="checkbox"/>		Screw and washer (M4 x 12)	6
<input type="checkbox"/>		Screw (M4 x 6)	2
<input type="checkbox"/>		Spacer bolts (A, B, C)	A = 1 B = 1 C = 2

To install the HCO, you need the following tools:

- #2 Phillips screwdriver. A screwdriver is included with the HCO.
- Medium flat-blade screwdriver

Assembling the HCO

The HCO comes with a stopper unit, tray, and paper guides. (See the checklist on page 4 for a complete list of accessories.)

To attach these accessories to the HCO:

Step 1 Use the two screws (M4 x 6) to attach the stopper to the lower rear of the HCO. See Figure 5.

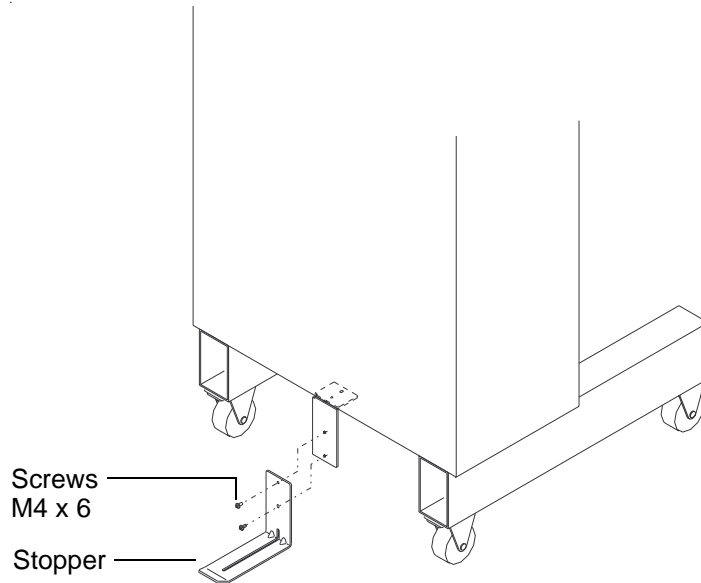

Figure 5 Attaching the stopper

Attaching the stopper prevents the HCO from tipping backward when you install the other HCO accessories.

Step 2 Slip the hooks on the back of the tray over the tray base. Use the six screws (M4 x 12) and washers to attach the tray to the tray base. See Figure 6.

The tray has six drilled holes for the screws.

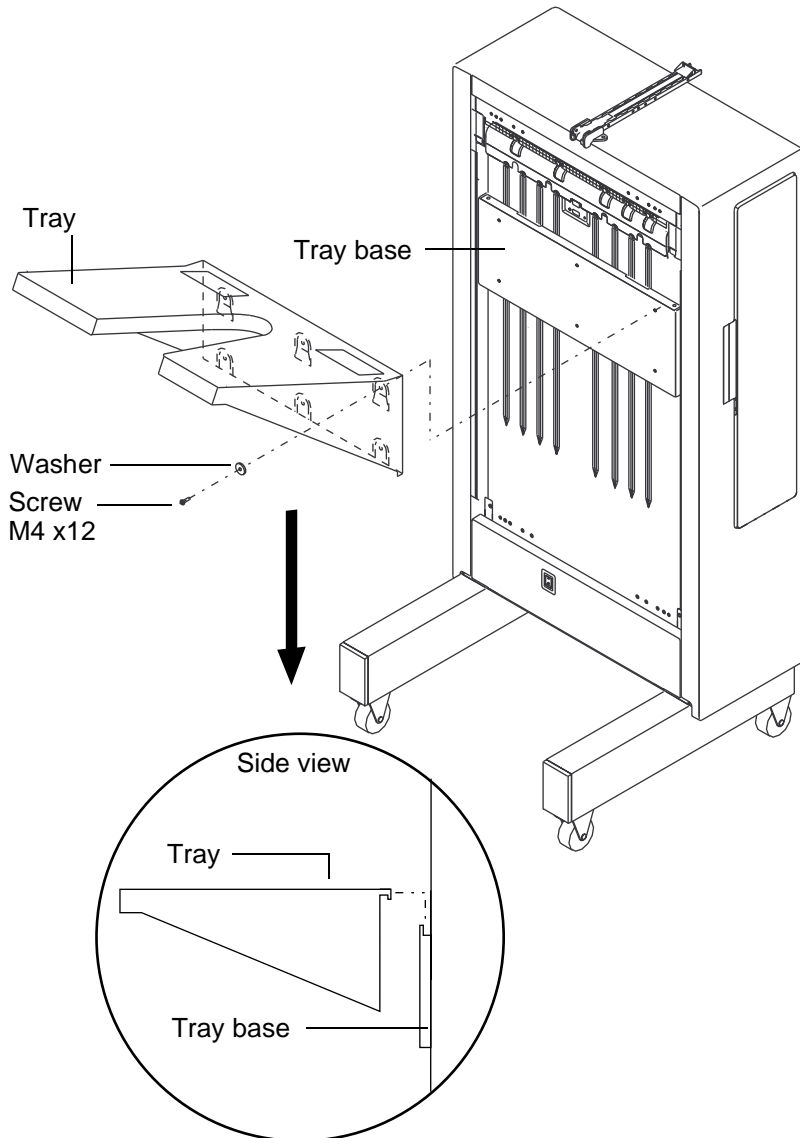

Figure 6 Attaching the tray to the HCO

Step 3 Locate the left paper guide and slide it through the left slot of the paper tray. See Figure 8.

The paper guides are labeled T,L for top left and T,R for top right. The shorter arm should be on top and the flange should point inward.

Step 4 Locate the paper size markers on the HCO and find the alignment hole that corresponds to the desired paper size. See Figure 7.

Note

Paper size markers appear on both the top and bottom of the HCO.

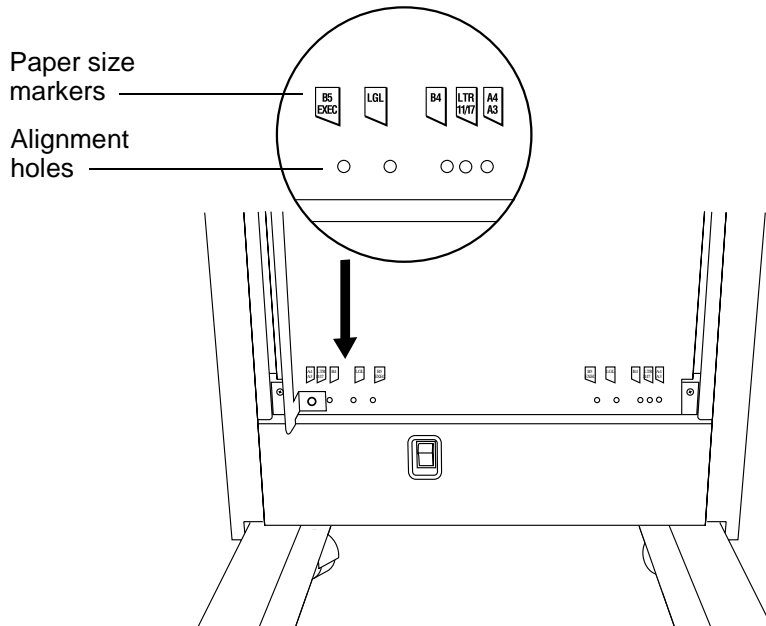

Figure 7 Paper size markers

Note

When you first install the HCO, Hewlett-Packard recommends you set the paper guides as far apart as possible (A3/A4 setting). You don't need to adjust the guides unless the HCO has paper stacking problems.

Step 5 With the paper size markers as a guide, use the captive knurled screws to attach the paper guide to the HCO.
See Figure 8.

Step 6 Repeat Step 3 through Step 5 for the right paper guide.

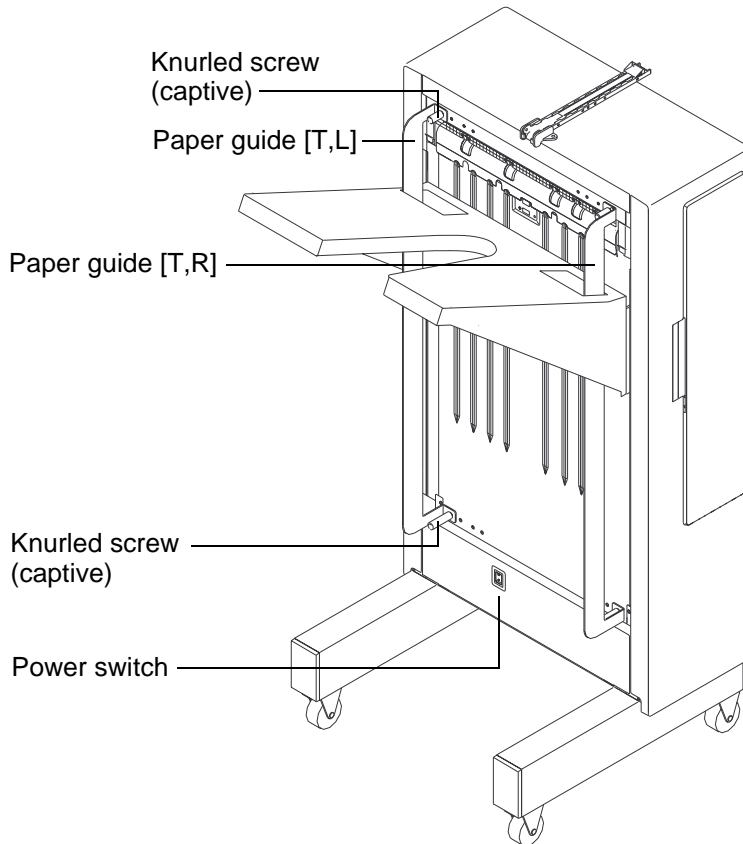

Figure 8 Left and right paper guides

Preparing the printer

After assembling the HCO, prepare the D640 printer for the HCO.

To prepare the printer:

- Step 1 Unscrew and remove the paper output cover from the printer. See Figure 9.

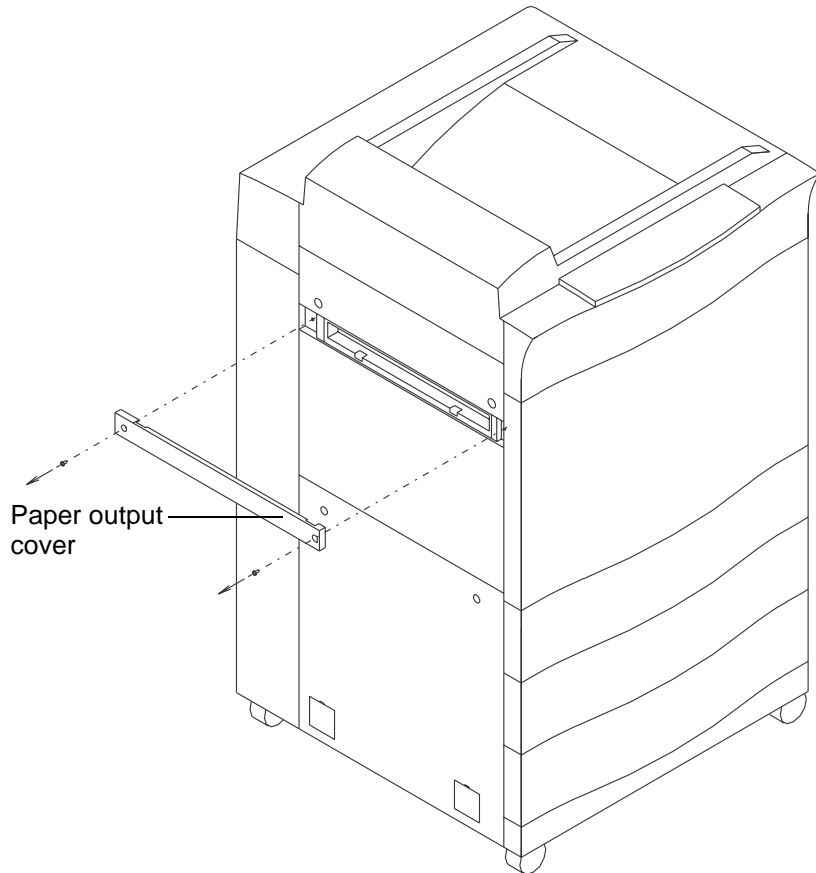

Figure 9 Removing the paper output cover

Step 2 Remove the left screw in the upper cover. See Figure 10.

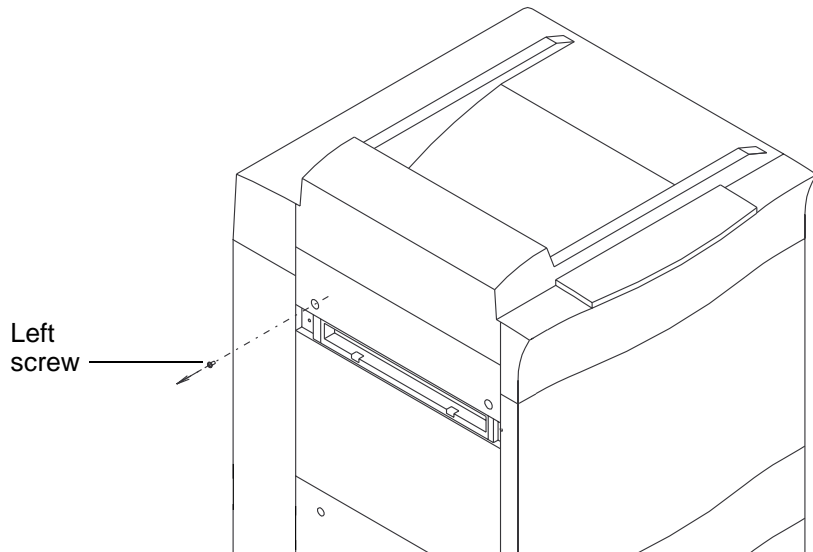

Figure 10 Removing the left screw in the upper cover

Step 3 Insert spacer bolt (B) into the upper cover hole (where the screw was). See Figure 11.

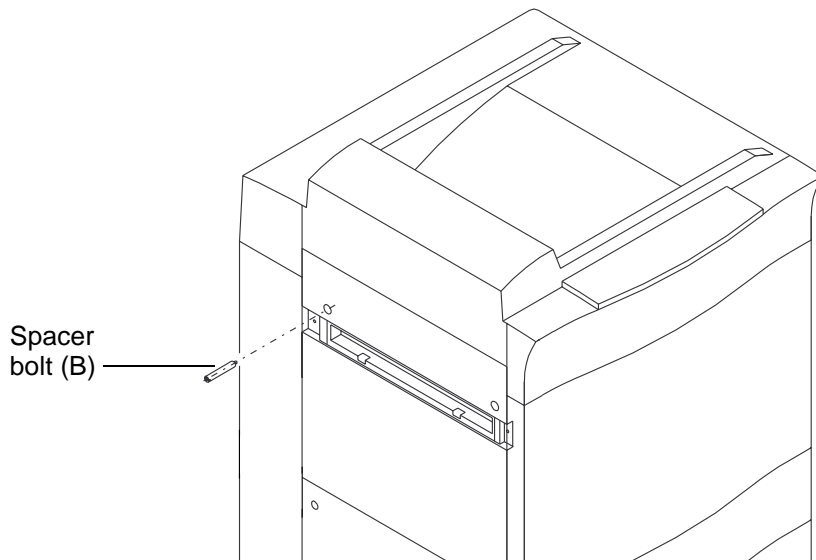

Figure 11 Inserting spacer bolt (B)

Spacer bolts are labeled A, B, and C. Make sure you use the correct bolt (B).

Step 4 Remove the right screw in the upper cover. See Figure 12.

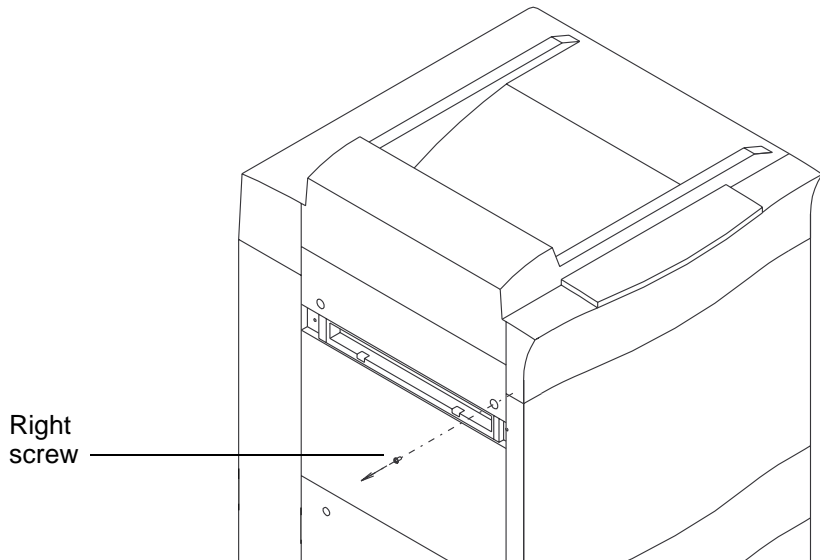

Figure 12 Removing right screw in upper cover

Step 5 Insert spacer bolt (A) into the hole where the screw was. See Figure 13.

Spacer bolts are labeled A, B, and C. Make sure you use the correct bolt (A).

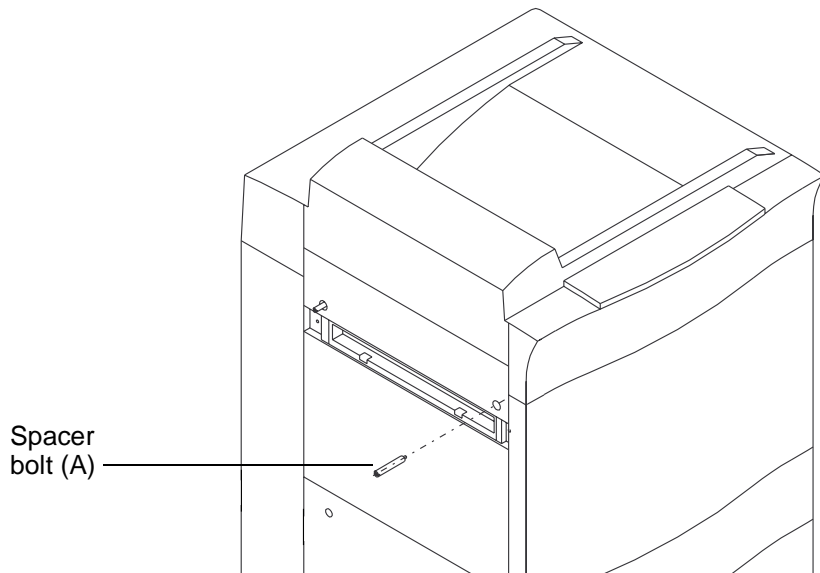

Figure 13 Inserting spacer bolt (A)

Step 6 Snap the paper output guide in place. See Figure 14.

If you have trouble inserting the paper output guide, make sure the guide is aligned correctly (parallel to the printer — not tilted up or down).

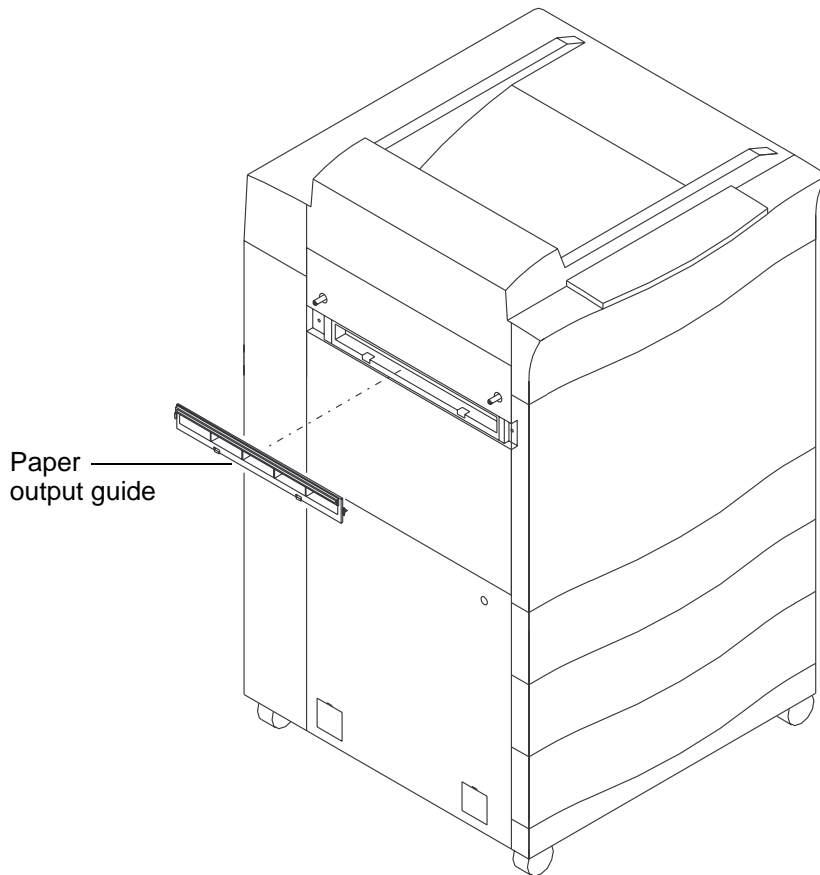

Figure 14 Attaching the paper output guide

Step 7 Remove the two screws in the lower cover. See Figure 15.

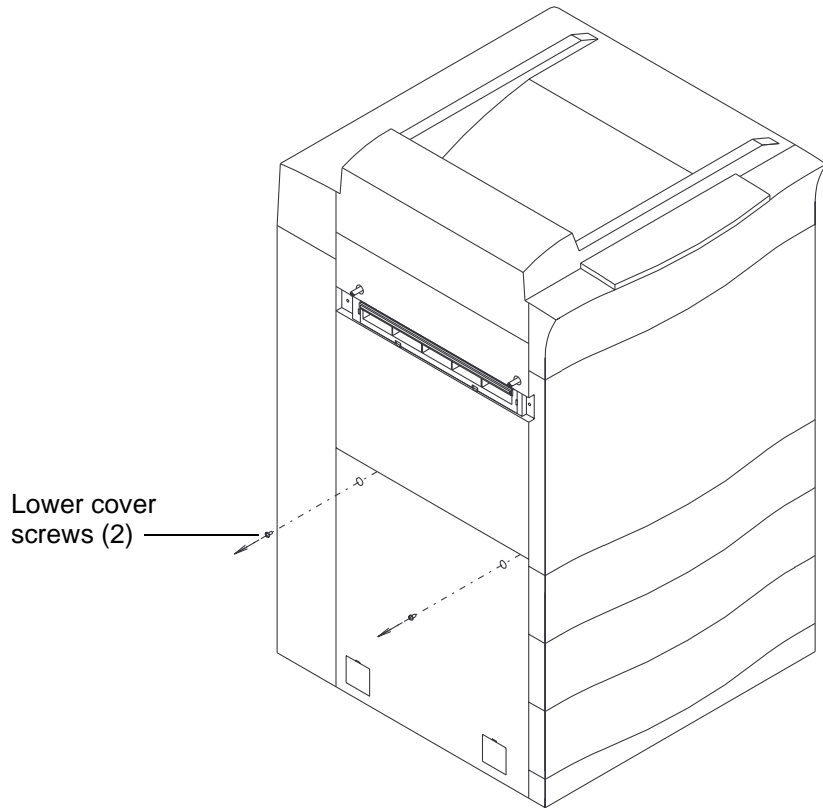

Figure 15 Removing the lower cover screws

Step 8 Insert two spacer bolts (C) into the lower cover holes (where the screws were). See Figure 16.

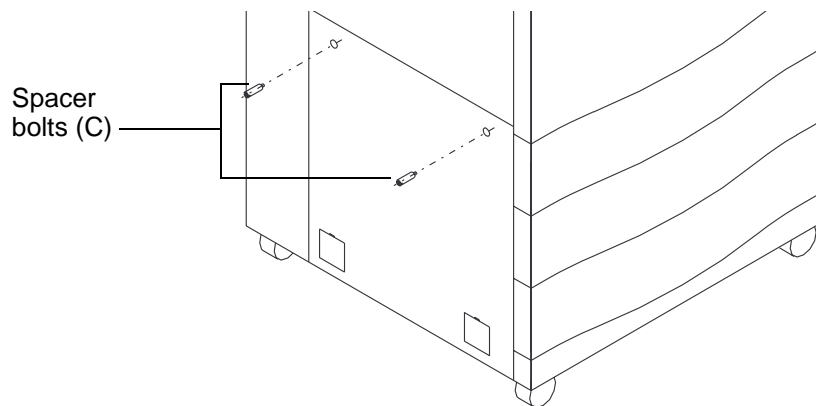

Figure 16 Inserting spacer bolts (C)

Spacer bolts are labeled A, B, and C. Make sure you use the correct bolt (C).

Step 9 Use a small, flat-bladed screwdriver to pop out the two small, square panels from the lower cover of the printer. See Figure 17.

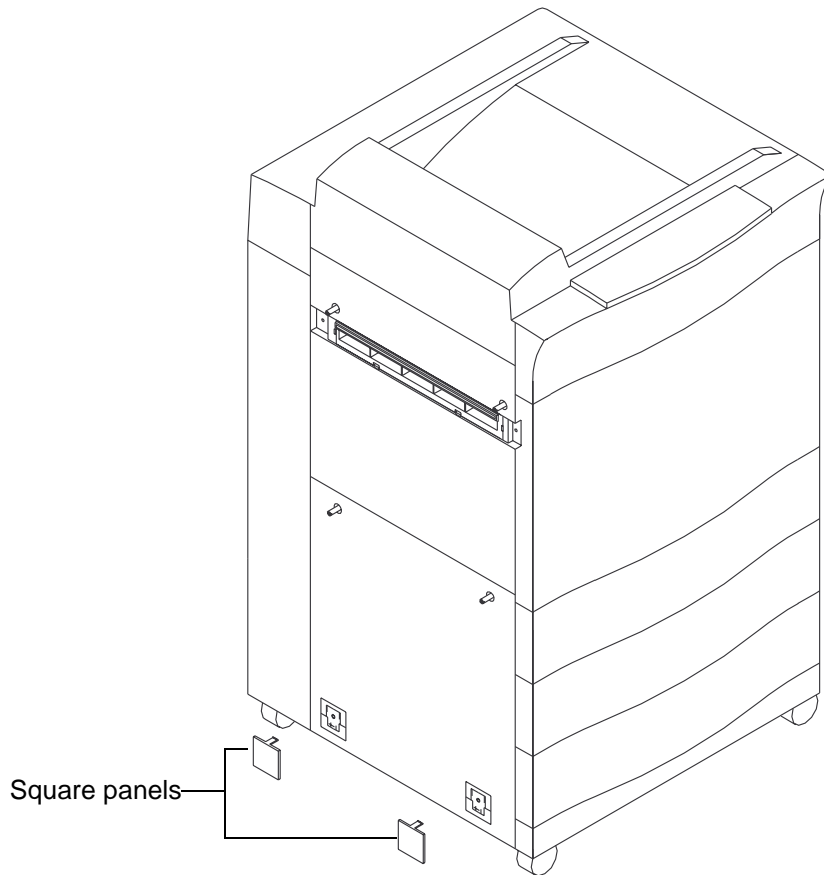

Figure 17 Removing square panels

Step 10 Use two captive screws to install the stopper guide where the square panels were located. See Figure 18.

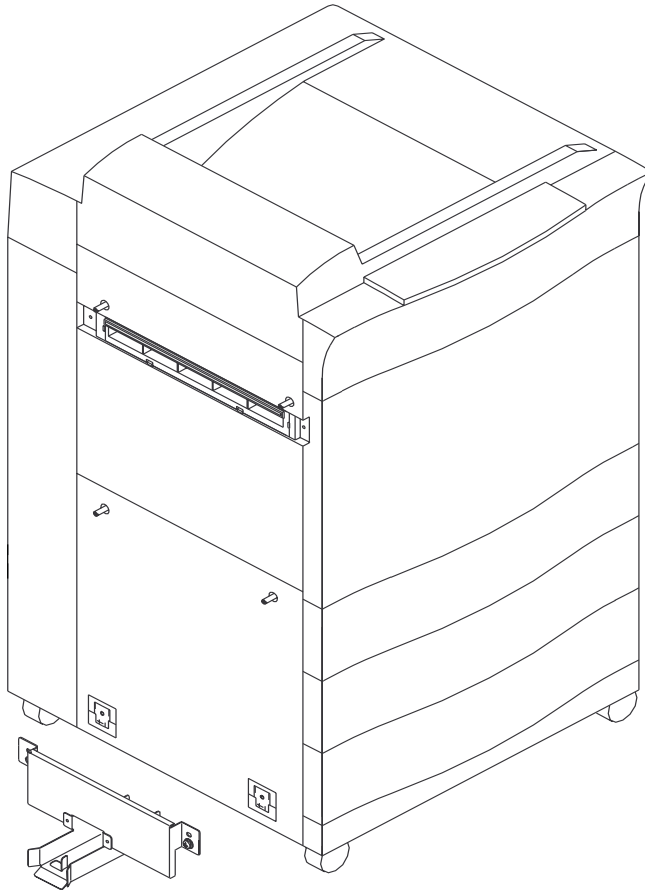

Figure 18 Attaching the stopper guide

Step 11 Use the four captive screws on the joining frame to attach the joining frame to the spacer bolts. See Figure 19.

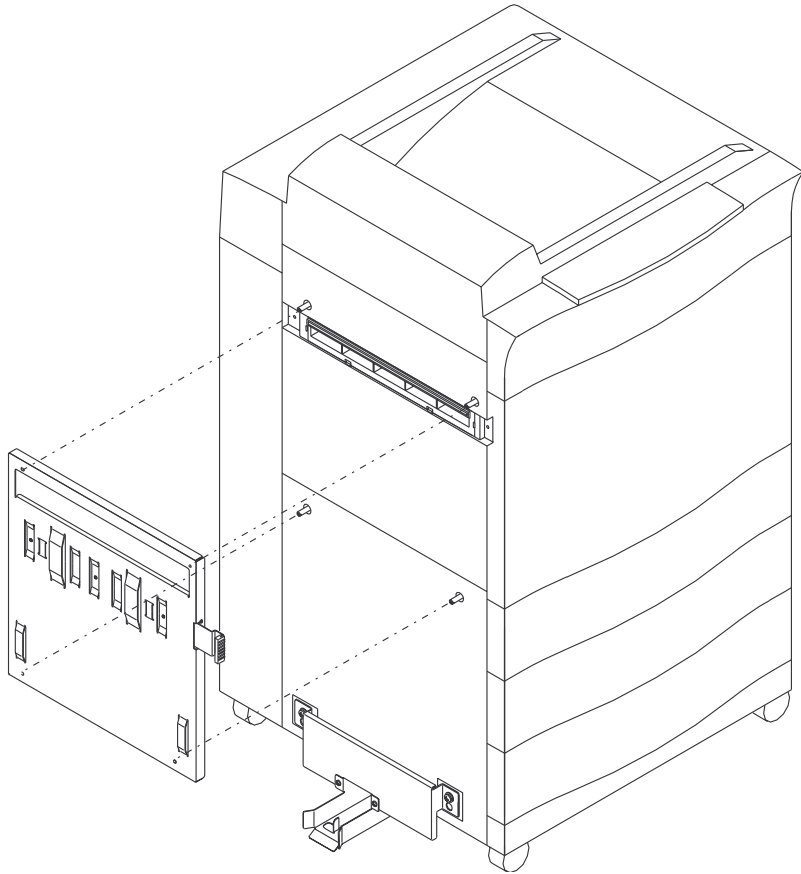

Figure 19 Attaching the joining frame

Connecting the HCO to the printer

After assembling the HCO and preparing the printer, you're ready to attach the HCO to the printer.

To connect the HCO to the printer:

Step 1 When connecting the HCO, lift the HCO a little to make sure the connecting pin on the stopper guide is aligned with the stopper hole on the HCO. See Figure 20.

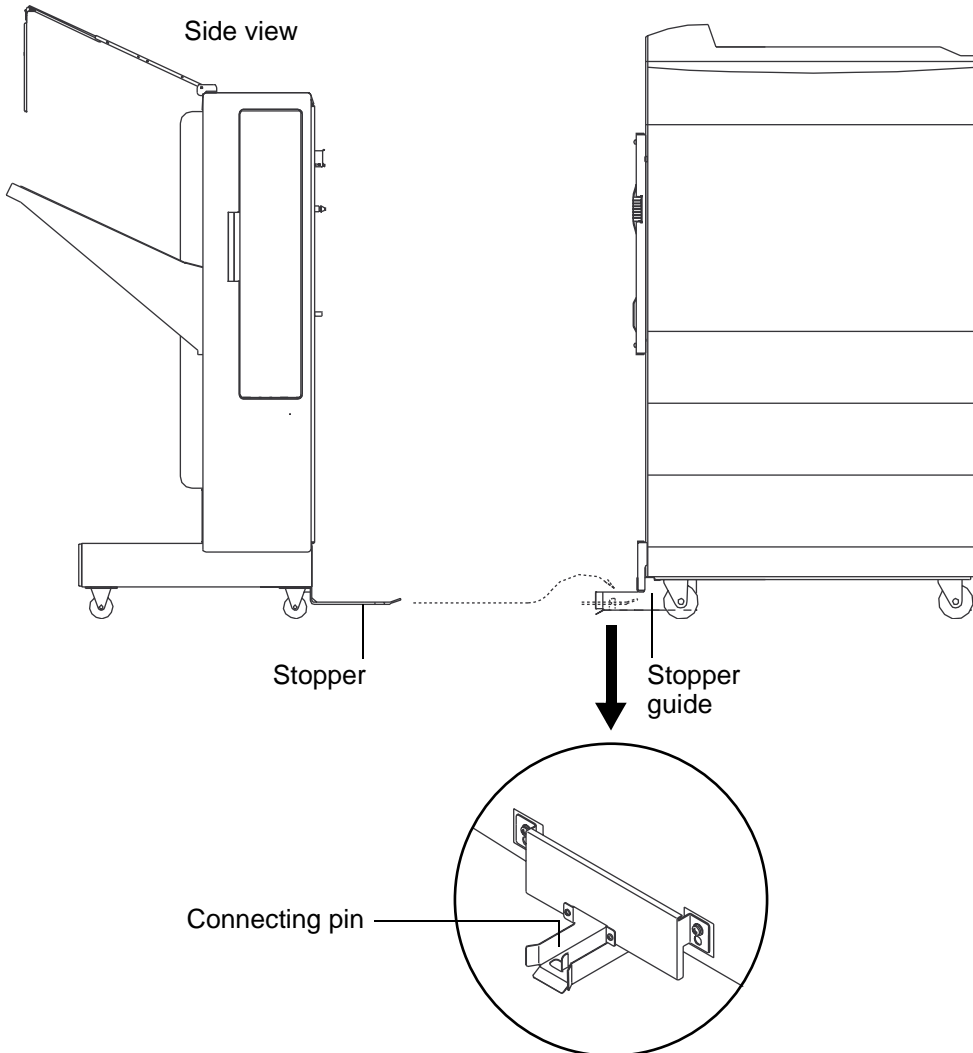

Figure 20 Aligning the stopper and stopper guide

Step 2 Push the HCO against the printer as shown in Figure 21.

The two metal pins on the back of the HCO are connected to the corresponding holes in the joining frame and the printer latch is engaged.

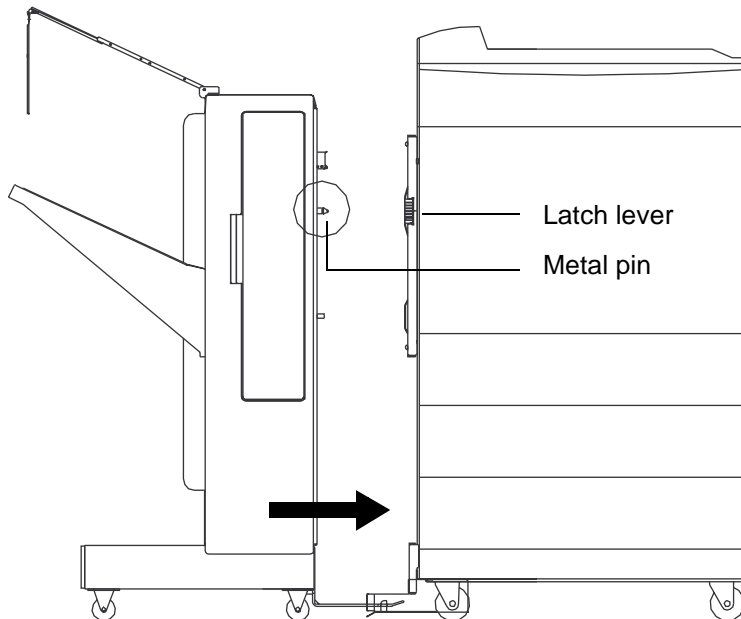

Figure 21 Connecting the HCO

Note

To disconnect the HCO from the printer, pull the latch lever towards you and move the HCO away from the printer.

Connecting cables and powering up

After the HCO and printer are attached, you're ready to connect the interface cable and power cable.

Step 1 Plug the interface cable from the HCO into the connector on the back of the printer. See Figure 22.

The connector is located at the back of the printer near the bottom.

Top view

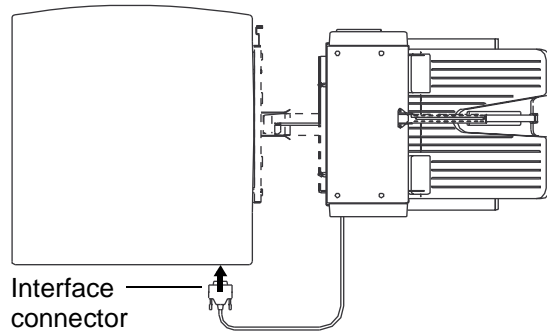

Side view

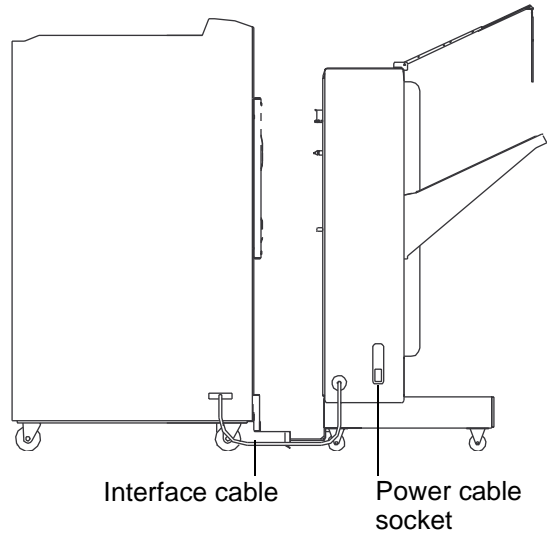

Figure 22 Connecting the interface cable and power cable

Step 2 Plug the socket end of the power cable into the power cable receptacle on the HCO. See Figure 22.

Step 3 Plug the other end of the power cable into a grounded outlet.

Step 4 Turn on the HCO power switch.

The power switch is on the lower front of the HCO. See Figure 8. It takes a few seconds for the HCO to perform power-up diagnostics.

Configuring the HCO

After you power up the HCO and check the connection, you're ready to configure your printer for the HCO.

To configure the HCO:

Step 1 Power up the printer.

If the HCO is connected properly, you should see an HCO icon on the printer's control panel.

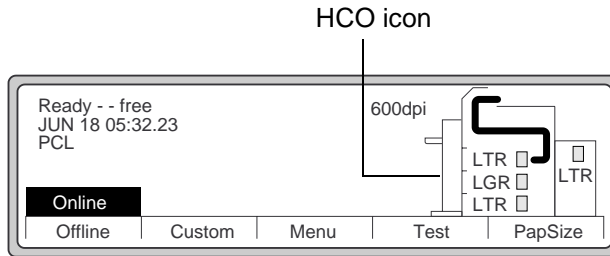

If the HCO icon doesn't appear, verify the following:

- the HCO power switch is on.
- the printer is connected to the HCO.
- the interface cable is connected.

Step 2 On the printer control panel, press the Menu button and select Printing.

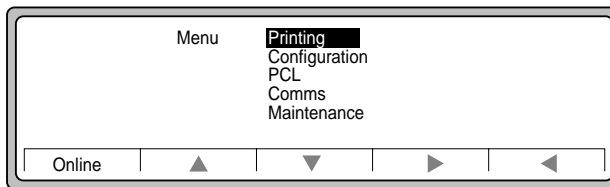

Note

For more information about using menus on the D640 printer, see the *Model D640 User Manual*.

Step 3 Open the Printing menu and select outbin.

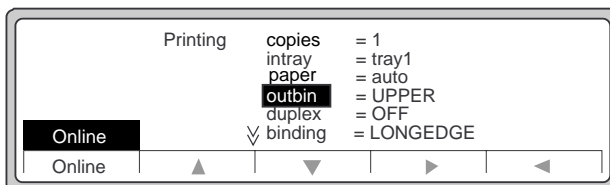

Step 4 Highlight either HCO-FACEDOWN or HCO-FACEUP and press Select.

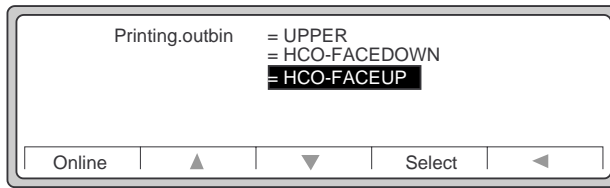

Step 5 Press Save.

The control panel changes to show that the HCO is set to act as the printer's main output tray.

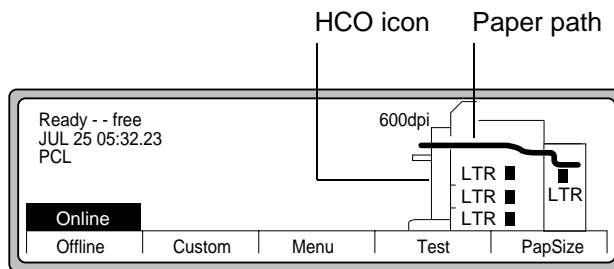

Congratulations! You've successfully installed the 3,000-sheet HCO. For more information on using the HCO, see Chapter 2.

2 Using the HCO

This chapter contains information on how to adjust the paper stopper and paper guides on the HCO and clear paper jams. It also includes a list of HCO messages that may appear on the printer's control panel.

Adjusting the paper stopper and guides

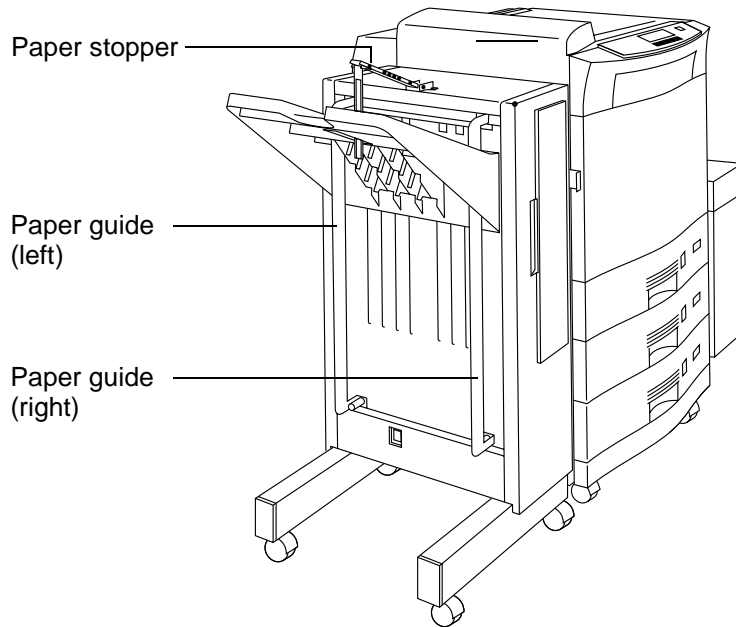

Figure 23 Paper stopper and paper guides

Adjusting the paper stopper

After you install the 3,000-sheet HCO, adjust the paper stopper to fit the size of paper you're using.

To adjust the paper stopper:

- Step 1 Locate the paper stopper on top of the HCO and position it as shown in Figure 23.
- Step 2 Locate the paper size markers on the stopper and slide the paper stopper to the desired paper size.

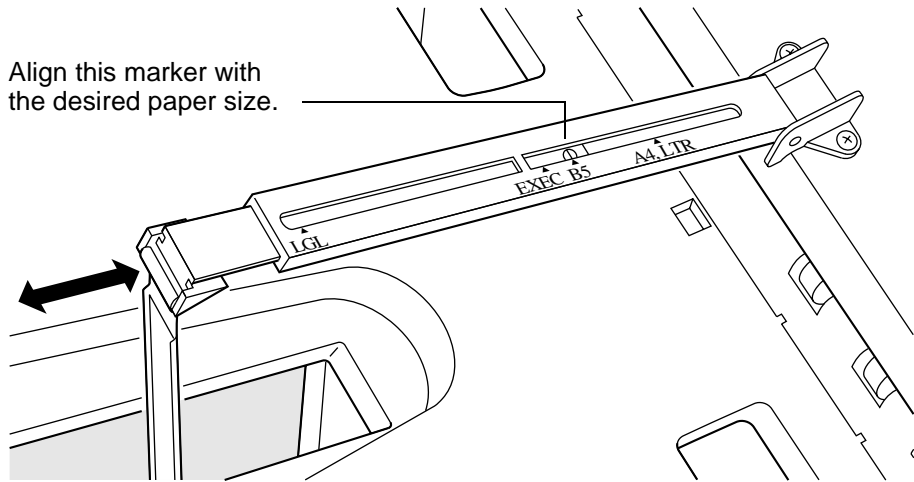

Figure 24 Paper size markers on the paper stopper

Paper size choices are: Legal, Executive, B5, and A4/LTR.

Note

If you're printing on A3 or Ledger paper, you don't need the paper stopper. Lift the paper stopper up and out of the way.

Adjusting the paper guides

Note

Hewlett-Packard recommends you set the paper guides as far apart as possible (A3/A4 setting). You don't need to adjust the guides unless the HCO has paper stacking problems.

To adjust the paper guides:

Step 1 Locate the paper guides on the HCO.

There are two paper guides, one on each side of the HCO.

Step 2 Release a guide by unscrewing the knurled screws that connect the guide to the top and bottom of the HCO.

Top of HCO

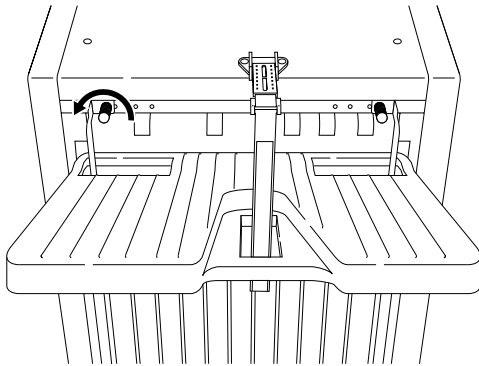

Bottom of HCO

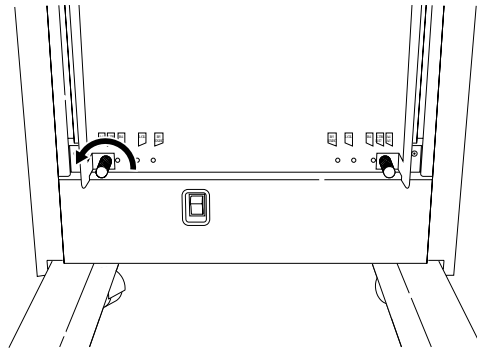

Figure 25 Releasing a paper guide

Step 3 Use the paper size markers at the top and bottom of the HCO to reposition the guide to the desired paper size.

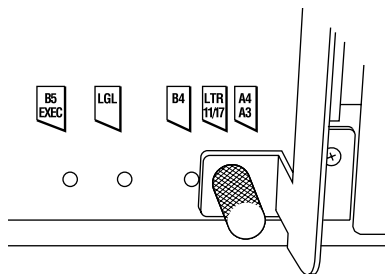

Figure 26 Paper size markers

Step 4 Tighten the knurled screws to reattach the guide to the printer.

Step 5 Repeat this procedure for the guide on the other side of the HCO.

Make sure you select the same paper size for each guide.

Clearing an HCO paper jam

If the HCO has a paper jam, you'll see an message on the printer's control panel. For example:

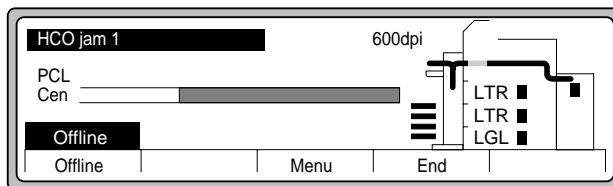

Clearing the HCO

To clear a paper jam in the HCO:

Step 1 Open the front door of the printer and remove any jammed paper in the reversing area. See Figure 27.

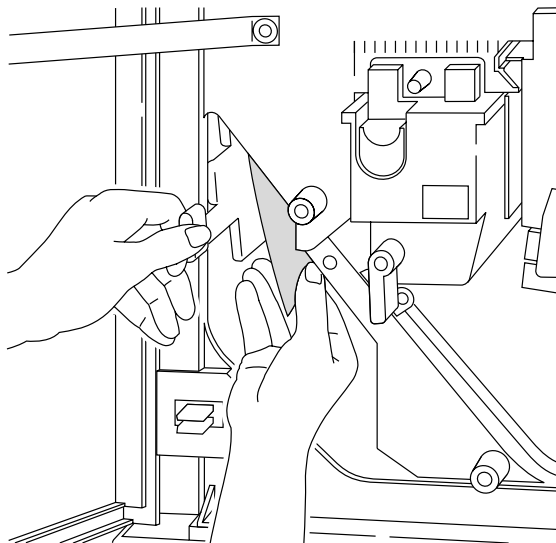

Figure 27 Clearing the reversing area

Step 2 Open the HCO door and locate HCO knob 1. See Figure 28.

Step 3 Rotate the knob counterclockwise to move paper from the HCO input area to the lower section.

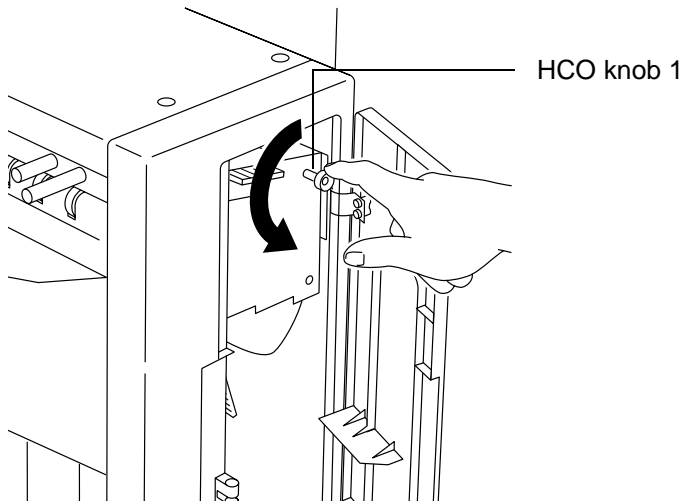

Figure 28 Rotating HCO knob 1

Step 4 Pull back lever 2 and remove any paper you find. See Figure 29.

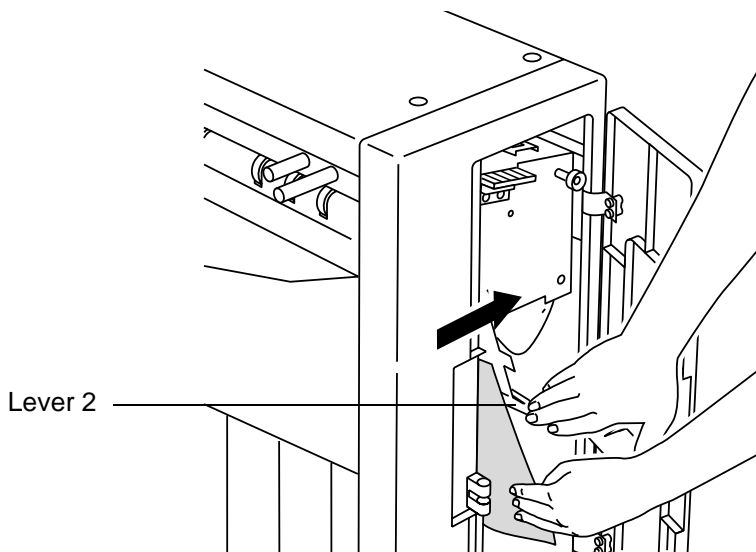

Figure 29 Pulling back lever 2

Step 5 If jammed paper is not visible, lift HCO lever 1 to see if any paper is jammed near the top of the HCO. See Figure 30.

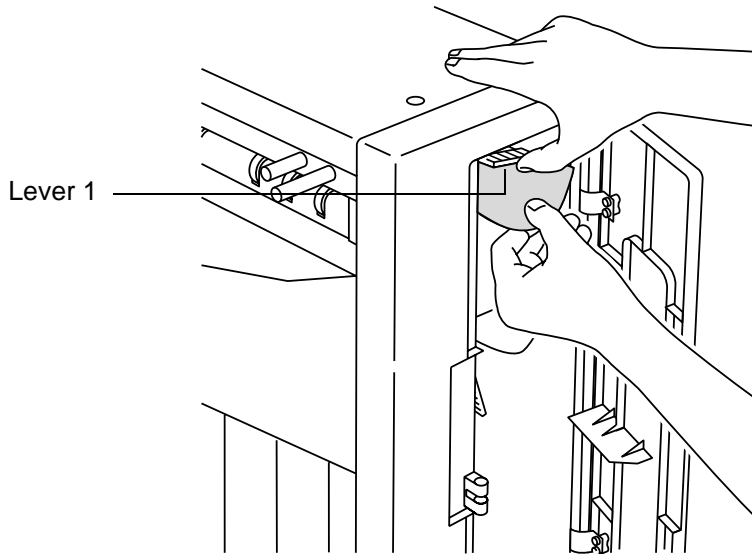

Figure 30 Lifting lever 1

Step 6 Rotate knob 1 to move any paper into view. See Figure 28.

Step 7 Remove any paper you find.

Note

When you check for jams, make sure you return the HCO levers to their proper closed positions. Otherwise, more jams will occur.

Separating the HCO from the printer

If jammed paper is still not visible, paper may be jammed between the HCO and the printer. You'll need to separate the HCO from the printer and check for jams.

To separate the HCO from the printer:

Step 1 Pull the HCO latch lever towards you and move the HCO away from the printer. See Figure 31.

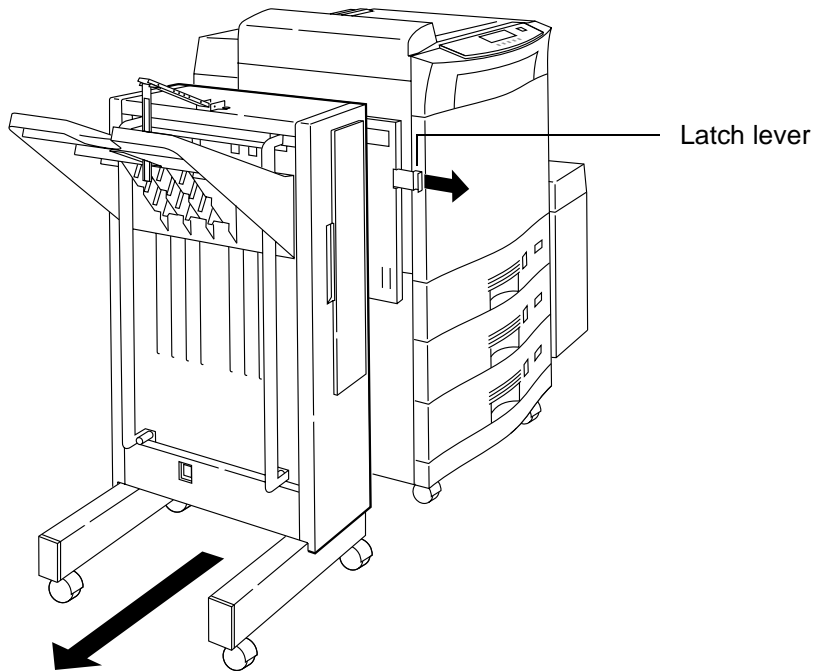

Figure 31 Separating the HCO from the printer

Move the HCO as far as the stopper that connects the HCO to the printer allows (about 1 inch).

Step 2 Check for any paper jammed between the HCO and the printer.

If no other paper jam messages appear on the printer's control panel, you're ready to reattach the HCO and resume printing.

If the control panel still shows the same jam, search the area again. If the control panel shows another type of jam, search the area indicated.

Messages

The following is a list of HCO messages that may appear on the printer's control panel

HCO Messages

Message	Remedy	Message type ^a
HCO jam1 HCO jam 2	Refer to "Clearing an HCO paper jam" on page 26 to clear the jam.	<i>Paper jam message:</i> Printing stops until the jam is cleared.
HCO cover open	Make sure the HCO cover is closed, the HCO power switch is on, and the HCO is connected to the printer.	<i>Error message:</i> Printing stops until the error is cleared.
Stack fault – Call engineer	<p>1. <i>Important:</i> Before you call your HP service representative, verify the following:</p> <ul style="list-style-type: none"> ● the HCO cover is closed. ● the HCO power switch is on ● the HCO is connected to the printer and the interface cable is connected. <p>2. Restart the printer and the HCO. If the message still appears, call your HP service representative.</p>	<i>Call engineer message:</i> This message may appear incorrectly, when the HCO is disconnected from the printer.
Error code: SVC D8 HCO stacker alarm	<p>1. Verify the following:</p> <ul style="list-style-type: none"> ● the HCO interface cable is connected to the printer. ● the HCO's power cable is plugged into a working power outlet. ● The HCO's power switch is on. <p>2. Press clear. If the error code returns, call your HP service representative.</p> <p>3. To continue printing without the HCO, disconnect the HCO interface cable and restart the printer.</p>	<i>Call engineer message:</i> Stops the printer and takes it offline.

HCO Messages

Message	Remedy	Message type ^a
HCO not ready	<ol style="list-style-type: none">1. Verify the following:<ul style="list-style-type: none">● the HCO interface cable is connected to the printer.● the HCO's power cable is plugged into a working power outlet.● The HCO's power switch is on.2. Press clear. <p>If the error message returns, cycle power on the printer and HCO. The HCO takes a few seconds to perform power-up diagnostics.</p> <ol style="list-style-type: none">3. If the error message returns, call your HP service representative.	<i>Call engineer message:</i> Stops the printer and takes it offline.

a. For more information about types of messages, see the *D640 User Manual*.

3 Specifications, Regulatory Information

This chapter contains specifications and regulatory information for the 3,000-sheet HCO.

Specifications

Note

The specifications in this document are preliminary and subject to change.

HCO paper handling specifications

HCO paper handling specifications

Item		Specifications
Processing Speed		40 ppm
Paper	Size	Letter, Legal, Ledger, Executive, A3, A4, A5, B4(JIS), B5(ISO)
	Type	Plain paper, Label paper, Transparency, Bond paper, Pre-punched paper, 64 to 90g/m ²
Paper capacity		3,000 sheets (75g/m ²)

HCO physical specifications

HCO physical specifications

Item	Specifications	
Dimensions	Width	16.1 inches (408 mm)
	Depth	17.4 inches (446 mm)
	Height	36.0 inches (913 mm)
Service area	Front	25.6 inches (650 mm)
	Back	33.5 inches (850 mm)
	Right	33.5 inches (850 mm)
Weight	66 pounds (30 kilograms)	

HCO electrical specifications

HCO electrical specifications

Item	Specifications	
Input power	Voltage	100 to 120 VAC \pm 10% 200 to 240 VAC \pm 10%
	Phase	Single-phase
	Frequency	50/60 Hz
Power consumption	180 VA or less than during operation	
Heat production	95 kcal per hour (380 BTU/hr)	

HCO environmental specifications

HCO environmental specifications

Ambient condition	Operating	Non-operating
Temperature	15 to 35 °C	-40 to +70 °C
Humidity	20 to 80% RH (no condensation) 40 to 60% RH optimal	20 to 80% RH (no condensation) 40 to 60% RH optimal
Temperature and humidity gradients	15 °C per hour or less and 30% RH per day or less (no condensation)	

Safety and regulatory information

For safety and regulatory information on the 3,000 page HCO, refer to the safety and regulatory information provided in the *D640 User Manual*. In addition, the following regulatory information applies.

Australia EMC



This symbol indicates compliance with Australian standard AS/NZS 3548:1995.

HP Declaration of Conformity



<p align="center">DECLARATION OF CONFORMITY according to ISO/IEC Guide 22 and EN 45014</p>

Manufacturer's name: Hewlett-Packard Company
Manufacturer's address: 19420 Homestead Road
Cupertino, California 95014, USA

declares that the product

Product name: 3000-page HCO for Model D640 Printer
Model number: C5638A
Product options: n/a

conforms to the following Product Specifications:

Safety: IEC 950:1991 + A1, A2, A3 / EN 60950:1992 + A1, A2
EMC: CISPR 22: 1993 / EN 55022:1994 Class A
EN 50082-1:1992
IEC 801-2:1991 / prEN 55024-2 (1992) 4kV CD, 8kV AD
IEC 801-3:1984 / prEN 55024-3 (1991) 3 V/m
IEC 801-4:1988 / prEN 55024-4 (1992) 1 kV Power Lines
0.5 kV Signal Lines

Supplementary Information:

The product herewith complies with the requirements of the EMC Directive (89/336/EEC) and the Low Voltage Directive (73/23/EEC) and carries the CE marking accordingly:

The product was evaluated and tested with the C5620B (HP Model D640) printer.

September 1, 1997

Office of the Quality Manager

European Contact: Your local Hewlett-Packard Sales and Service Office or Hewlett-Packard GmbH, Department HQ-TRE, Herrenberger Straße 130, D-71034 Böblingen (FAX:+49-7031-14-3143)

Index

A

- A3/A4 paper settings 8
 - See also paper sizes
- accessories
 - checking 4
 - unpacking 2
- adjusting
 - paper guides 25–26
 - paper stopper 24
- aligning
 - paper output guide 13
- alignment holes, for paper sizes 8
- assembling, HCO 6–9
- attaching
 - joining frame 17
 - paper guides 8
 - paper output guide 13
 - stopper 6
 - stopper guide 16
 - tray 7
- Australia EMC certification 35

B

- buttons
 - Menu 21
 - Save 22

C

- certification, Australia EMC 35
- checking, accessories 4
- clearing, paper jams 26–29
- configuring
 - printer for HCO 21–22
- connecting
 - HCO to printer 18–20
 - interface cable 19
 - power cable 20
- connecting pin, on stopper guide 18
- control panel 21, 29, 30
- Cover open message 30

D

- Declaration of Conformity 36
- diagnostics, power-up 20, 31
- dimensions, of HCO 34
- disconnecting, HCO from printer 19

E

- error messages 30

F

- flange, on paper guide 8
- front door, of printer 26

G

- grounded outlet 20

H

- HCO
 - connecting to printer 18–20
 - error messages 30
 - knobs and levers 27
 - powering up 20
 - printing without 30
 - separating from printer 19, 28–29
 - specifications 33–34
 - unpacking 2–3
 - using 23–31
- HCO door 3, 27
- HCO icon, on control panel 21
- HCO input area 27
- HCO, assembling 6–9
- HCO-FACEDOWN setting 22
- HCO-FACEUP setting 22
- heat production 34
- high capacity output. See HCO
- HP Declaration of Conformity 36
- humidity specifications 34

I

- indicator, paper path 22
- installing, spacer bolts 11, 12, 14
- installing. See attaching
- interface cable 4, 30
 - connecting 19
- interface connector 20
 - See also interface cable

J

- Jam messages 30
- jams. See paper jams
- joining frame 4
 - attaching 17

K

- knobs and levers, inside HCO 27, 28
- knurled screws 4, 9, 25

L

- latch lever. See printer latch
- levers and knobs, inside HCO 27

M

- markers, paper size 8, 24, 25
- Menu button 21
- menus, Printing 21

N

- Not ready message 31

O

- outbin setting 21
- output tray, using HCO as 22

P

- packing material 3
- pages per minute 1, 33
- paper capacity 33
- paper guides 4, 23
 - adjusting 25–26
 - attaching 8
- paper input guide 3
- paper jams 30
 - clearing 26–29
 - preventing 3, 28
- paper output cover, removing 10
- paper output guide 4
 - attaching 13
- paper path indicator 22
- paper sizes 1, 8, 24, 25, 33
- paper stacking problems 8
- paper stopper 23
 - adjusting 24
- pins, on back of HCO 19
- power cable 2, 4
 - connecting 20
- power cord. *See* power cable
- power requirements 34
- power switch 9, 20, 30
- power-up diagnostics 20, 31
- preparing, printer for HCO 10–17
- preventing, paper jams 3
- printer
 - configuring for HCO 21–22
 - powering up 21
 - preparing for HCO 10–17
 - separating from HCO 28–29
- printer latch 19, 29
- Printing menu 21
- printing, without HCO 30
- problems
 - error messages 30
 - stacking paper 8, 25
- processing speed 33

R

- regulatory information 35
- related documents 1
- removing
 - paper output cover 10
 - screws 12, 14
 - square panels 15
 - upper cover 11
- reversing area, clearing paper jams in 26

S

- safety information 35
- Save button 22
- screwdriver 5, 15
- screws 5
 - knurled 9, 25
 - lower cover 14
 - M4 x 12 7
 - M4 x 6 6
 - on joining frame 17
 - on stopper guide 16
 - upper cover 12
- service area specifications 34
- settings
 - HCO-FACEDOWN 22
 - HCO-FACEUP 22
 - outbin 21
 - paper size 8
- spacer bolts 5
 - inserting 11, 12, 14
- specifications 33–34
- square panels, removing 15
- Stack fault message 30
- Stacker alarm message 30
- stacking problems. *See* paper stacking problems
- stopper 4, 29
 - attaching 6
- stopper guide 4
 - attaching 16
 - connecting pin 18
- SVC D8 error message 30

T

- temperature specifications 34
- tipping, preventing 6
- tray 4
 - attaching 7
- tray base 7

U

- unpacking
 - accessories 2
 - HCO 2–3
- upper cover, removing 11
- user manual 2, 4

W

- washers 5, 7
- weight specifications 2, 34

READER COMMENT SHEET
System Peripherals Operation
D640 Cut Sheet Printer 3,000-Sheet HCO
Manual Part Number C5638-90001
October 1997

A reader comment sheet helps us improve the accuracy and readability of this document. It also gives you a way to make suggestions and recommend improvements to the product.

Serious errors, such as technical inaccuracies that may render a program or mechanical device inoperative, should be reported immediately to your Hewlett Packard Response Center or directly to a Support Engineer. This ensures that such problems are addressed as quickly as possible.

Editorial suggestions (please include page, table, and figure numbers):

Recommendations (attach additional information, if needed):

Name:

Date:

Job Title:

Telephone:

Company:

Address:

Hewlett-Packard has the right to use submitted suggestions without obligation, with all such ideas becoming the property of Hewlett-Packard.

Fold and Tape



NO POSTAGE
NECESSARY
IF MAILED
IN THE
UNITED STATES

BUSINESS REPLY MAIL

FIRST CLASS PERMIT NO. 1070, CUPERTINO, CA

– POSTAGE WILL BE PAID BY ADDRESSEE –

Publications Manager
HP 5000 Systems Printers
Systems Peripherals Organization

Hewlett-Packard Company
19111 Pruneridge Avenue, MS 44MC
Cupertino, California 95014

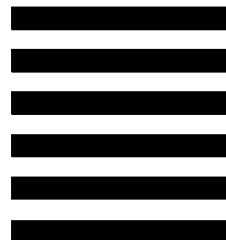

Fold and Tape



**Manual Part No.
C5638-90001**

Copyright © 1997
Hewlett-Packard
E1097
Printed in USA